

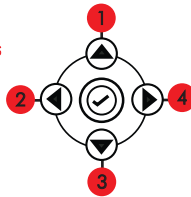

Display Control Keys

- 1: speed dial
- 2: received calls
- 3: missed calls
- 4: placed calls



Placing a Call

using the handset:
Pick up phone and dial number, or dial number, then pick up phone.

using speakerphone:
1: With handset on-hook, press:
- any assigned line key, or
- **☎** button, or
- **NewCall** soft key
2: Dial the number.

using the optional headset
1: With the headset connected, press:
- any assigned line key, or
- **☎** button, or
- **NewCall** soft key.
2: Dial the number.

Answering A Call

using the handset:
Pick up the handset.
using speakerphone:
With the handset on-hook, press:
- **☎** button, or
- the line key, or
- **Answer** soft key
using the optional headset:
Press **☎**

Call Transfer

- 1: During a call, press the **Transfer** soft key (the active call is placed on hold).
- 2: If a blind transfer is required, press the **Blind** soft key.
- 3: Call the number to which you want to transfer the call or access the number from a call list, and press the **Dial** soft key.
- 4: After the ring-back sound is heard, or after the party answers, press **Transfr** to complete the transfer.

Call Hold & Resume

During a call, press **☎** or the **Hold** soft key. Press the **Resume** soft key, or the line key to retrieve the call.

If multiple calls are on hold on a single line, use the **▲** or **▼** keys to select the desired call, then press the **Resume** soft key to return to this call.

If calls are on hold on more than one line, the call details can be viewed by pressing & holding the desired line key. If a line key is pressed briefly, the first call on hold on that line will be retrieved.

During a call, users can alternate between handset, headset or handsfree modes by pressing the **☎** or **☎** keys, or picking up the handset



Display Control Keys

- 1: speed dial
- 2: received calls
- 3: missed calls
- 4: placed calls

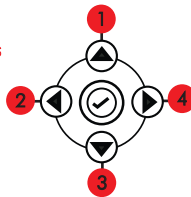

Placing a Call

using the handset:
Pick up phone and dial number, or dial number, then pick up phone.

using speakerphone:
1: With handset on-hook, press:
- any assigned line key, or
- **☎** button, or
- **NewCall** soft key
2: Dial the number.

using the optional headset
1: With the headset connected, press:
- any assigned line key, or
- **☎** button, or
- **NewCall** soft key.
2: Dial the number.

Answering A Call

using the handset:
Pick up the handset.
using speakerphone:
With the handset on-hook, press:
- **☎** button, or
- the line key, or
- **Answer** soft key
using the optional headset:
Press **☎**

Call Transfer

- 1: During a call, press the **Transfer** soft key (the active call is placed on hold).
- 2: If a blind transfer is required, press the **Blind** soft key.
- 3: Call the number to which you want to transfer the call or access the number from a call list, and press the **Dial** soft key.
- 4: After the ring-back sound is heard, or after the party answers, press **Transfr** to complete the transfer.

Call Hold & Resume

During a call, press **☎** or the **Hold** soft key. Press the **Resume** soft key, or the line key to retrieve the call.

If multiple calls are on hold on a single line, use the **▲** or **▼** keys to select the desired call, then press the **Resume** soft key to return to this call.

If calls are on hold on more than one line, the call details can be viewed by pressing & holding the desired line key. If a line key is pressed briefly, the first call on hold on that line will be retrieved.

During a call, users can alternate between handset, headset or handsfree modes by pressing the **☎** or **☎** keys, or picking up the handset

3-Way Conference Calls

creating a three-way conference call:

- 1: Call the first party.
- 2: Press the **Confmc** soft key to create a new call (the active call is placed on hold).
- 3: Place a call to the second party.
- 4: When the second party answers, press the **Confmc** soft key again to join all parties in the conference.
- 5: When a conference has been established, press the **Split** soft key to split the conference into two calls on hold.

Voice Mail

Message Waiting Indicator LED & individual line LED indicators on the phone will flash. A stutter dial tone will replace the normal dial tone to indicate that message(s) are waiting at the message center.

listen to voice messages:

- 1: Press **Messages** to access voice messaging
- 2: Follow voice prompts to listen to messages.

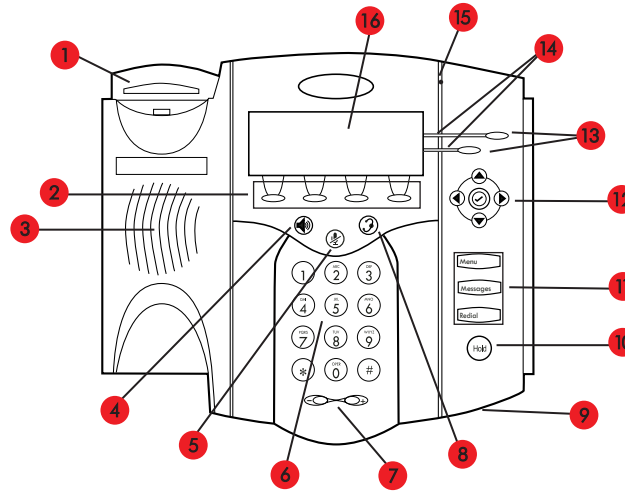

- 1: hookswitch
- 2: soft keys
- 3: speaker
- 4: speakerphone
- 5: microphone mute
- 6: dial pad
- 7: volume keys
- 8: headset

- 9: hands-free microphone
- 10: hold key
- 11: feature key
- 12: display control keys
- 13: line/speed dial keys
- 14: line indicators
- 15: indicator
- 16: graphic display

[For a more detailed user guide please go to:
www.polycom.com/voip]

3-Way Conference Calls

creating a three-way conference call:

- 1: Call the first party.
- 2: Press the **Confmc** soft key to create a new call (the active call is placed on hold).
- 3: Place a call to the second party.
- 4: When the second party answers, press the **Confmc** soft key again to join all parties in the conference.
- 5: When a conference has been established, press the **Split** soft key to split the conference into two calls on hold.

Voice Mail

Message Waiting Indicator LED & individual line LED indicators on the phone will flash. A stutter dial tone will replace the normal dial tone to indicate that message(s) are waiting at the message center.

listen to voice messages:

- 1: Press **Messages** to access voice messaging
- 2: Follow voice prompts to listen to messages.

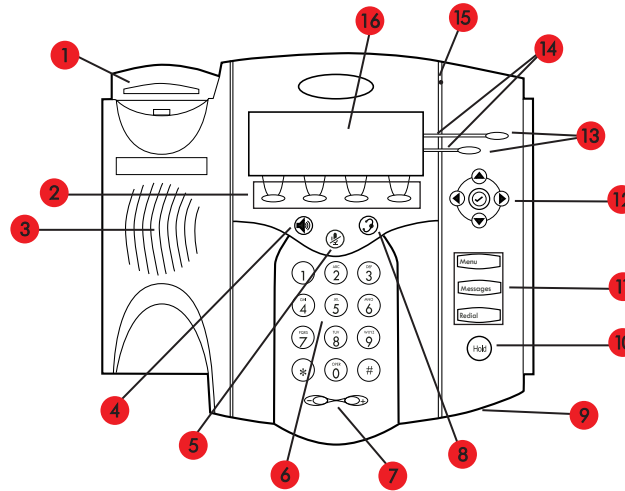

- 1: hookswitch
- 2: soft keys
- 3: speaker
- 4: speakerphone
- 5: microphone mute
- 6: dial pad
- 7: volume keys
- 8: headset

- 9: hands-free microphone
- 10: hold key
- 11: feature key
- 12: display control keys
- 13: line/speed dial keys
- 14: line indicators
- 15: indicator
- 16: graphic display

[For a more detailed user guide please go to:
www.polycom.com/voip]